

REVISIONS			
REV	DESCRIPTION	DATE	APPROVED
--	--	--	--

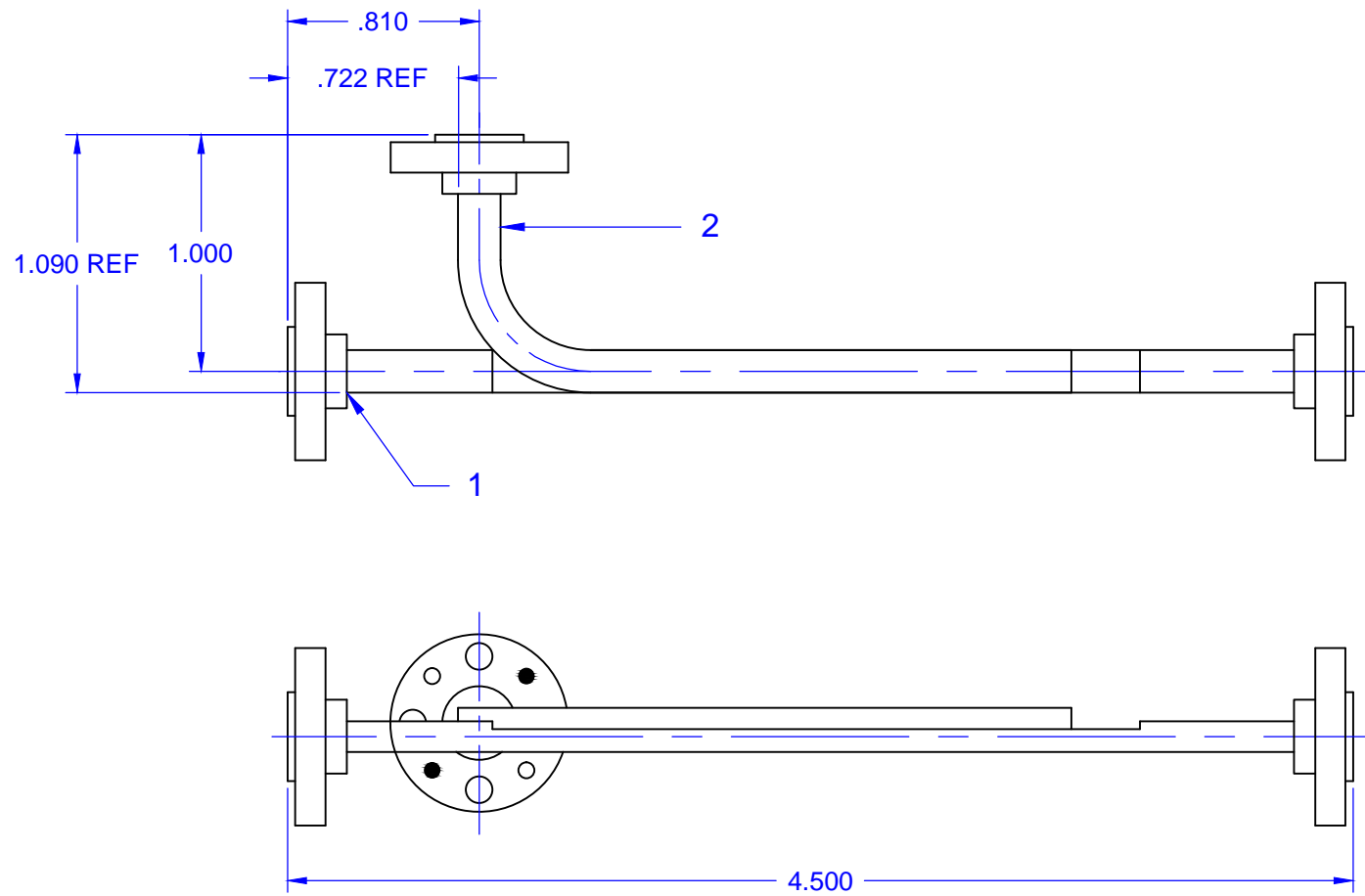

1	21665	W BAND LOAD	--
1	21323	CROSS ARM	2
1	21322	THRU ARM	1
QTY	PART NUMBER	DESCRIPTION	ITEM
UNLESS OTHERWISE SPECIFIED		 THIRD ANGLE PROJECTION	Mi-Wave Millimeter Products Inc. 559W-10/387 OUTLINE
ALL SURFACES $\sqrt{.32}$			
DIMENSIONS ARE IN INCHES TOLERANCES ARE: DECIMALS: .1234 +/- .0005 .123 +/- .005 .12 +/- .01 ANGLES: +/- .5 DEGREES		DRAFTING: K.S. APPROVED: M.S. DATE: 12/10/2013	
ALL THREADS TO BE 2A OR 2B		SHEET NO. 1 OF 1 SIZE A DWG NO 22200	
REF DWG# 10102			